

# ST - III Series POWER SUPPLIES

## USER MANUAL

### Introduction

These instructions detail the installation and operation requirements for the ST20-III & ST35-III power supplies. These have been designed for operation in RV's providing a DC power system, with optional battery back up.

The units operate from 240Vac and provide an isolated 13.65Vdc output at 20A and 35A respectively for powering the load and charging of batteries. All the necessary protection and operating features for the load and batteries are provided. An optional DC input is also provided to enable charging of batteries and powering of the load from an external +13.8V DC power source.

The units are fully enclosed ready for direct wall mounting. All connections are at the rear of unit providing convenient wiring and installation. User access to all load and battery fusing has been provided from the front of the unit.

### Operation

**Safety:** Refer to the installation section before operating. Correct installation is the most critical factor in ensuring the safe use of the power supply. If every consideration of these instructions has been satisfied the power supply will be safe to operate.

If the AC supply cord is damaged it must be replaced by the manufacturer, its service agent or similarly qualified persons in order to avoid hazard.

The unit is rated to charge a single 12V (up to 6 cells) lead acid battery at 100Ahr Capacity.

### Functional Diagram:

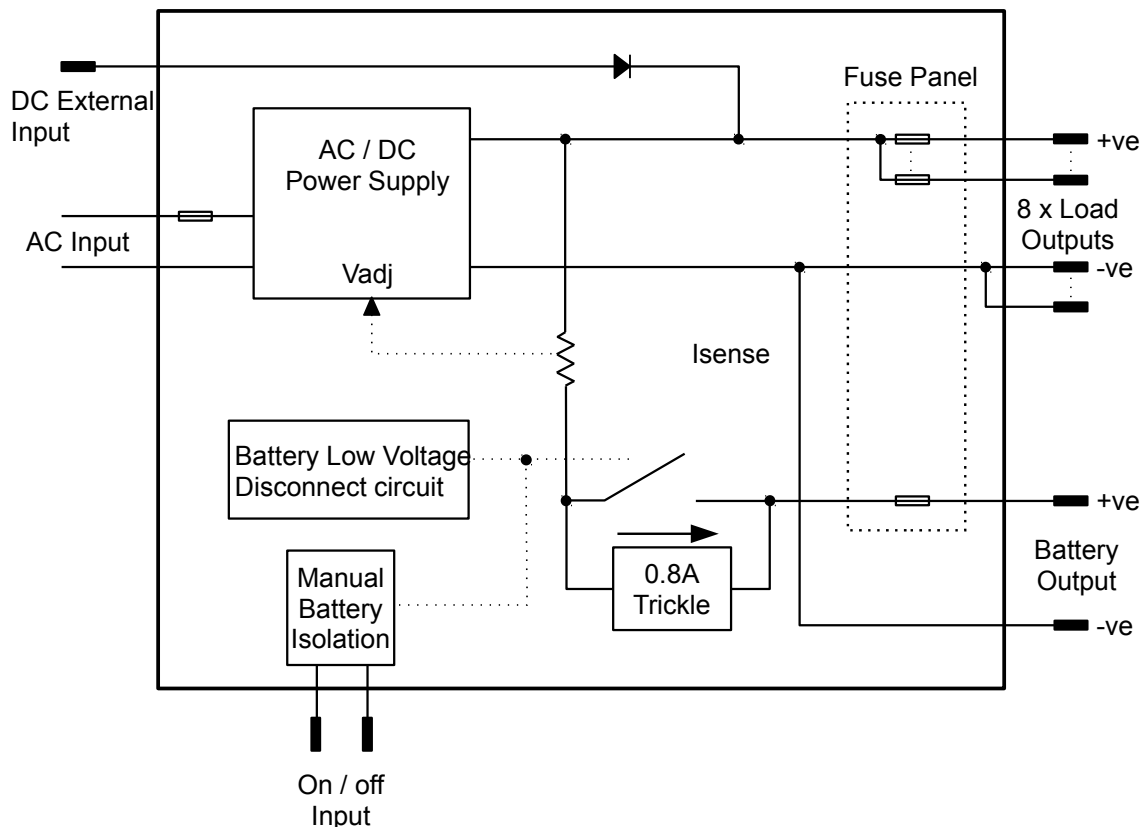

Figure 1 Functional Block Diagram

**AC/DC Power Supply:** This provides an isolated 13.65Vdc output for powering of the load and float charging of the battery. Battery current is sensed and monitored by the power supply to ensure that the maximum charging current is not exceeded.

**Battery Features:** The power supply provides full battery management as per the following.

The power supply is a four stage battery charger with Boost (VBoost = 14.05V), Float (VFloat = 13.65V), Store (VStore = 13.25V) and Trickle charge modes to ensure long battery life.

*Battery Charging* current is limited to a maximum of 10A (ST20-II) and 15A (ST35-II). This provides optimum life for the batteries.

To charge at the maximum battery charge current above, ensure the load current plus battery current is equal or less than the maximum output current. The charging current will be reduced in situations where the difference between the rated output current and the load current (the available charging current), is less than the maximum charging current.

Also note that the battery current sense is provided in the “Batt +ve” battery output. For this feature to work, the load “+ve” and battery “Batt +ve” should not be cross connected. (Appliances should not be connected to both the “Batt +ve” and “+ve” terminals of the power supply. Appliances should be connected to the “+ve” and “-ve” load terminals).

*Low Voltage Disconnection* of the batteries is provided to prevent deep discharge of the battery. Automatic reconnection occurs when battery voltage recovers.

*Battery Current Drain* is less than 2mA.

*Trickle Charge* to the battery is always present. When the battery voltage is below the LVD (Low voltage disconnect) re-connect voltage (<10V and the mains power or auxiliary power is available, the battery will be charging at 0.8A. When the battery voltage is sufficient (>10.5V for first power up, 11.5V and 11.7V for subsequent reconnection with and without mains respectively) the LVD will connect the battery and allow float charging at 10A/15A (ST20-II/ST35-II). The Trickle Charge feature is provided to allow “very” flat batteries to be charged at a rate, which will extend their life.

**Remote Battery Isolate Switch:** The ST-III series power supplies allow for connection to a remotely positioned switch that provides a manual disconnection of the battery from the loads and the main charger. When the switch contacts are closed, the battery will be isolated from the loads.

***NOTE: When the battery is isolated from the loads using the battery isolate switch it will NOT charge at the 10/15 A rate even if the mains is connected to the power supply. In this condition it will ONLY charge at the Trickle charge rate.***

**Front Panel Indicators:** The ST-III series power supplies have 3 indicators visible on the front fascia.

Mains(GREEN) – is illuminated when mains power is present.

Battery(ORANGE) – is illuminated when the battery is connected to the loads.

Fault(RED) – is illuminated when there is a fault with the power supply.

Battery fuse Blown<sup>1</sup>

Battery connected reverse polarity<sup>2</sup>

Shut down condition (UV and OT)<sup>3</sup>

Main PCB micro controller malfunction<sup>4</sup>

*Notes*

1. *Flashing 1s ON, 1s OFF.*

2. *Solid ON.*

3. *Flashing 1s ON, 1s OFF, with no battery connected the power supply may be in hiccup mode which will cause the indication to flash with random duty cycle and frequency.*
4. *Fault Led= Solid On, All other leds = OFF, irrespective of actual mains or LVD status.*

**Auxiliary Power Input:** The power supply terminal “Aux In +VE” provides an alternative option for powering of the load and float charging of the batteries when mains voltages are not present. This input is to be powered by a suitable +12V system. (i.e. CAR). The voltage of the auxiliary power source should not exceed 14.8 volts.

When operating via the external input, current and voltage control for the battery must be provided from the external source. The ST20-II/35-II does not provide battery current limit or voltage control when operating in this configuration. Trickle Charge is still functional when powered through “Aux In +VE” terminal of power supply.

Suitable fuse protection must be provided for this input. A fuse rating not exceeding 20 Amps for ST20-II and 30 Amps for ST35-II must be used.

Solar power should be connected directly across the battery terminals with a voltage regulator in series. A solar panel voltage regulator with maximum output voltage not exceeding 14.8 volts must be used at all times. Failure to use a voltage regulator may result in power supply damage.

Generator 12 volt outputs should not be connected across battery terminal whilst battery is connected to power supply or connected to the “Aux In +VE” terminal of power supply. Serious power supply damage or internal explosion may occur. If a flat 12 volt battery has to be charged using the generators 12 volt output, it should first be disconnected from the power supply. Once battery has being charged it can then be reconnected to power supply.

Power supply unit should only be powered from either 240VAC mains or Auxiliary Power (Auxiliary Power also includes solar power) but **not both**. Failure to do so may result in damage to power supply.

**Protection:** the power supply provides automatic protection for overload including short circuit, over-voltage, over-temperature and reverse connected battery. In such instances the Fault indicator will illuminate and the power supply will shut down. It will attempt to automatically restart every 5 seconds until such case that the fault is removed.

**Fusing:** Each load circuit and the battery have been fused to provide fault protection and discrimination. Refer to servicing section for maximum fuse ratings.

**CAUTION:**

This appliance is **not** intended for use by young children or infirm persons without supervision.

Young children should be supervised to ensure that they do not play with the appliance.

In order to avoid hazard when the supply cord becomes damaged, the cord must only be replaced by the manufacturer or its service agent or similar technically qualified person.

Power supply unit should only be powered from either 240VAC mains or Auxiliary Power (Auxiliary Power also includes solar power) but not both. Failure to do so may result in damage to power supply.

**Installation**

**Host Equipment:** The host equipment must ensure that access to the unit (other than the front panel) by the user is prevented.

**Personnel:** Installation is to be carried out only by suitably qualified personnel.

**Ventilation:** Provide a minimum of 80mm clearance above, below and behind the unit. The final enclosure must also provide adequate ventilation to the outside world (or larger internal cavity) to prevent the build up of hot air. Failure to provide adequate ventilation will mean the unit may prematurely trip thermal shut-down. A minimum ventilation of 20,000mm<sup>2</sup> to the outside world must be provided.

**CAUTION**

**Do not install unit in same compartment as batteries or flammable material such as petrol. Ensure that the installation meets the ventilation requirements above.**

**Mechanical and Mounting:**

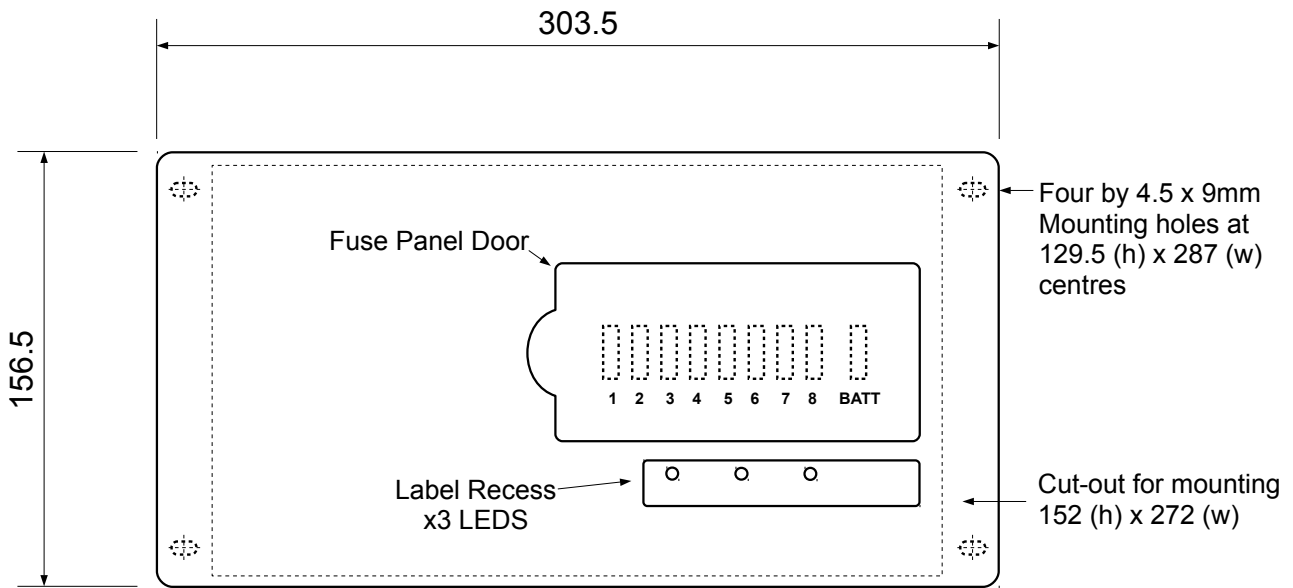

Depth of unit is 125mm

After mounting unit, clip on the front fascia (ensure that all locking clips have engaged) and secure with screw located inside the fuse panel door.

**Orientation:** The unit is to be installed with the front fascia in a vertical plane. Failure to do this will cause premature temperature shut-down.

### Wiring Up

**Mains:** This is pre cabled and fitted with AS/NZ mains plug ready for connection to internal GPO. Ensure that the connection to the mains supply is in accordance with the national wiring rules, and that the earth connection is installed.

**Load, Battery and External DC Input Connections:** Connectors are 0.8 x 6.3mm QC tabs. Use mating QC connector suitable for cable size. Connector pin-out is shown below.

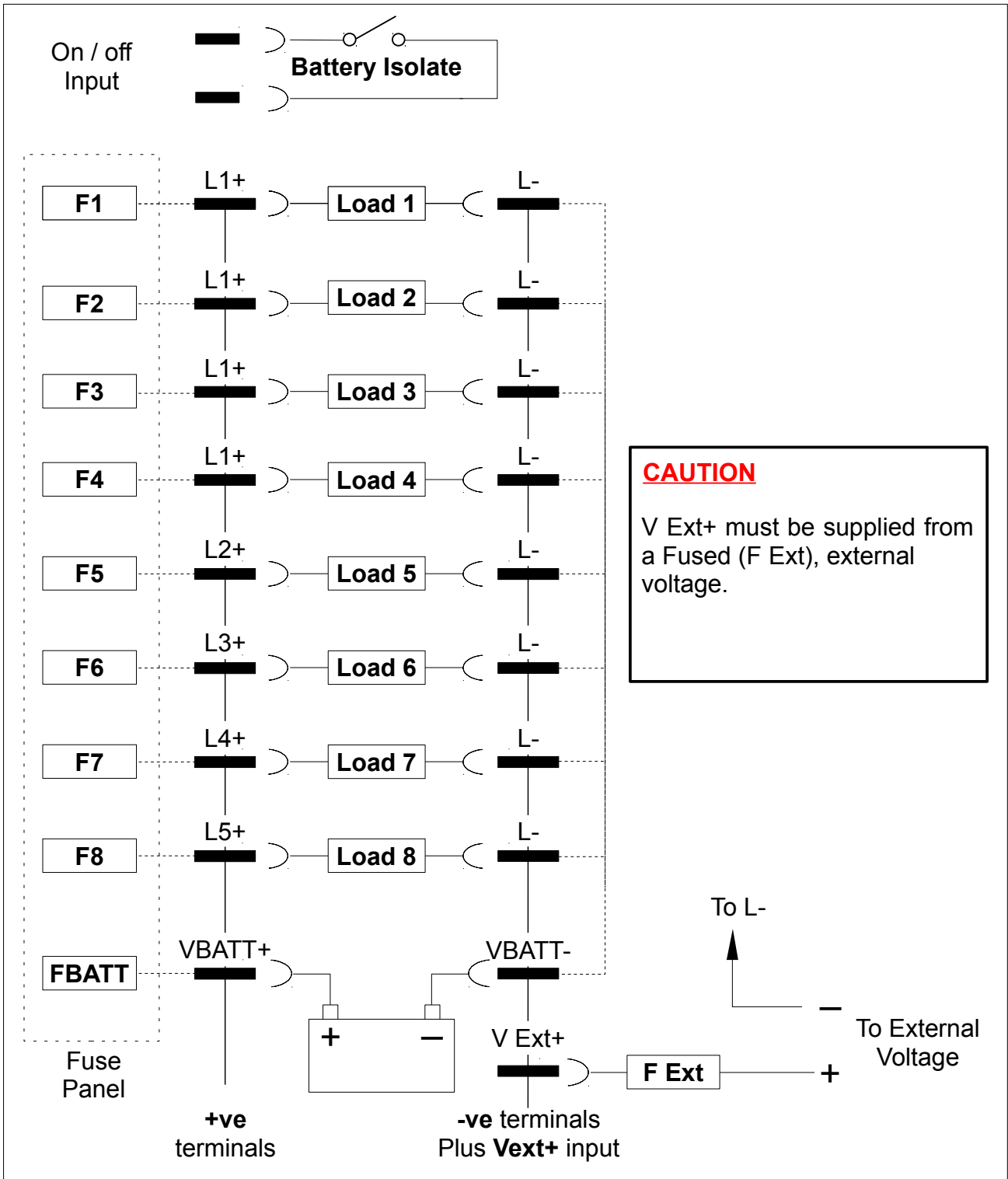

**Cabling sizes:** DC cables must be sized to carry the maximum full load current and not exceed the system volt drop requirements. The following cable sizes are recommended.

| Current   | AWG | mm <sup>2</sup> |
|-----------|-----|-----------------|
| 0 -10 A   | 18  | 1.0             |
| 10 - 20 A | 14  | 3.0             |
| 20 - 30 A | 10  | 5.5             |

Where cables pass through any part of a metal panel or cover, ensure that a cable gland or bush is fitted to the hole.

#### **Battery Connection Procedures:**

Battery should be connected as per the following steps.

Turn power supply off and all 12 volt equipment connected to power supply.

Connect positive battery terminal to “Batt +VE” power supply terminal.

Connect negative battery terminal to “Batt -VE” power supply terminal or negative chassis ground.

If battery is connected to chassis, ensure a connection exist from chassis to “Batt –VE” terminal of power supply.

#### **Battery Disconnection Procedures:**

Battery should be disconnected as per the following steps.

Turn power supply off and all 12 volt equipment connected to power supply.

Disconnect negative battery terminal connection to “Batt –VE” power supply terminal or negative chassis ground.

1. Disconnect positive battery terminal to “Batt +VE” power supply terminal.

#### **Batteries**

When using batteries with this product always consult with the battery manufacturer for a detailed description of the installation, use and maintenance of the battery.

Ensure battery has been charged for several days before a major camping trip (Leave the power supply on for at least 2 – 5 days with battery connected).

This product is suitable for charging 12V-Sealed Lead-Acid (SLA) batteries including Valve-Regulated Lead-Acid (VRLA) batteries both Absorbed Glass Mat (AGM) and Gel batteries. One or two batteries with max.100Ah capacity each can be charged. Charging current is limited to 10A (ST20-II) and 15A(ST35-II).

**CAUTION:**

Ensure that there is good ventilation from the battery area.

Ensure that cable connections to batteries have the correct polarity and are protected against accidental short circuit.

Ensure that the shrouding supplied with the battery is fitted to the terminals

Provide visual notification that batteries are being used in area of use.

Before servicing a battery, disconnect the power supply.

Batteries are electrically alive at all times and must be treated with extreme caution. They can supply high short circuit currents, even if they appear damaged. Take care that dropping or touching of metal objects onto the battery cell does not cause short circuits. Remove any personal metal adornment such as a chain, watch or ring, which could cause short circuits and personal injury.

Do not charge non-rechargeable batteries. Failure to do so may result in the battery catching on fire or possible explosion.

**Servicing**

**Personnel:** This product contains hazardous voltages and energy hazards, which can result in death or injury. Only properly qualified service personnel may service it.

There are no internal user serviceable parts. Only the fuses located in the “fuse panel” located on the front panel are serviceable.

Isolate mains power, Vext and battery before servicing.

**Replacement of Fuses:** Only the DC output Load and Battery fuses may be replaced.

*Fuse ratings:* Load fuses 20A max, Battery Fuse 35A max.

*Fuse types:* 32V Automotive Bussmann ATC series or Littelfuse 257 series or equivalent

## Specification

|  |  |
|--|--|
| <b>Input Voltage:</b>                      | ST20-II & ST35-II: 230 – 240Vac nominal, $\pm 10\%$ , 50/60Hz.<br>The power supply will withstand a 5 minute, +15% surge on the maximum nominal voltage  |
| <b>Input Surge:</b>                        | < 40A (cold start)   |
| <b>Hold-up Time:</b>                       | > 10mS at full load current and over nominal input voltage operating range   |
| <b>Output Current:</b>                     | ST20-II: 20A Continuous (load + battery current)<br>ST35-II: 35A Continuous (load + battery current)   |
| <b>Factory Set Voltage</b>                 | 13.65V +/- 0.1V (Vfloat)   |
| <b>Load Regulation:</b>                    | < 2%   |
| <b>Output Ripple Voltage:</b>              | < 150mV  |
| <b>Over Voltage Protection:</b>            | < 17V  |
| <b>Over Current Protection</b>             | ST20-II: 20A to 25A (load + battery current)<br>ST35-II: 35A to 38A (load + battery current)   |
| <b>Battery Current Limit</b>               | 10A $\pm$ 1A (ST20-II)<br>15A $\pm$ 1A (ST35-II)   |
| <b>Battery Connect/Disconnect</b>          | Connect: 10.50 $\pm$ 0.2V (Input Mains not present) and first power up<br>Connect: 11.70 $\pm$ 0.2V (Input Mains not present and not first power up)<br>Connect: 11.50 $\pm$ 0.2V (Input Mains present)<br>Disconnect: 10.0 $\pm$ 0.2V |
| <b>Battery Trickle Charge</b>              | 0.8A   |
| <b>Battery Drain</b>                       | < 2mA.   |
| <b>Efficiency:</b>                         | > 84%  |
| <b>Cooling Fan Operation ST35-II Only.</b> | Cooling fan on temperature of Transformer: 95C $\pm$ 3 degrees.<br>Cooling fan off temperature of Transformer: 75C $\pm$ 3 degrees.  |
| <b>Ambient</b>                             | 0°C – 50°C   |
| <b>Weight:</b>                             | < 2kg  |
| <b>Standards</b>                           | Safety: AS/NZS 60335-1, AS/NZS 60335-2-29 & AS/NZS 61558<br>EMC CISPR 22 class A   |
| <b>Compliance:</b>                         | ERAC+ACMA (RCM)  |



## Battery Management

To maintain the battery in a good state of health an intelligently controlled charging algorithm is used. The purpose is to ensure that the correct voltages are applied to the battery terminals at the appropriate times throughout it's usage cycle.

To prevent corrosion on the battery positive plate due to continuous float charging current ( $V_{float} = 13.65V$ ), the unit utilises a storage mode voltage ( $V_{store} = 13.25V$ ) when no activity on the battery is detected. This extends the battery life. During store mode, the unit exits to boost mode ( $V_{boost} = 14.05V$ ) for 15 minutes every 24hrs to maintain charge in the battery. If battery activity is detected during store mode it exits automatically into float mode.

For any decision making involving the “loss of mains” detection there is a 2 minute mains debounce period where there must be no mains signal present on the mains detect input for the “no mains” signal to be valid.

A detailed description of the operational requirements for the charging algorithm is described below:

| Present Output Set Voltage | Conditions Required to Enter Operational State                 | Operational State  | New Output Set Voltage  |
|----------------------------|--|--|-------------------------|
| N/A                        | Microcontroller first power up.                                | Initial application of power to the microcontroller either from 240VAC mains input or connection of a battery to the battery input (Includes Auxiliary power). | Vfloat                  |
| Vfloat (No Mains Input)    | Mains input detected after loss of mains for less than 1 hour. | Float charging mode with mains input voltage detected (set 24 hour timer).   | Vfloat                  |
| Vboost                     | Mains input voltage was detected for more than 15 minutes.     | Float charging mode with mains input voltage detected (set 24 hour timer).   | Vfloat                  |
| Vfloat                     | No mains input voltage is detected.                            | Float charging mode with no mains input voltage detected (set 1 hour timer).   | Vfloat (No mains input) |
| Vstore                     | No mains input voltage is detected.                            | Float charging mode with no mains input voltage detected (set 1 hour timer).   | Vfloat (No mains input) |
| Periodic_Vboost            | No mains input voltage is detected.                            | Float charging mode with no mains input voltage detected (set 1 hour timer).   | Vfloat (No mains input) |

| Present Output Set Voltage | Conditions Required to Enter Operational State  | Operational State  | New Output Set Voltage  |
|----------------------------|---|--|-------------------------|
| Vfloat (No Mains Input)    | Mains input voltage was detected after being absent for more than 1 hour.                     | Loss of mains, boost charging mode, active after resumption of mains input supply (set 15 minute boost timer). | Vboost                  |
| Vboost (No Mains Input)    | Mains input voltage was detected (this condition must also reset the 15 minute boost period). | Loss of mains boost charging mode, active after resumption of mains input supply (set 15 minute boost timer).  | Vboost                  |
| Vboost                     | No mains input voltage is detected.   | Boost charging mode while no mains is detected.  | Vboost (No Mains Input) |
| Vfloat                     | Mains input voltage was present for more than 24 hours.                                       | Battery storage mode (set 24 hour timer).  | Vstore                  |
| Periodic_Vboost            | Periodic boost voltage timer has timed out.   | Battery storage mode (set 24 hour timer).  | Vstore                  |
| Vstore                     | Battery storage mode timer has timed out.   | Periodic boost mode (set 15 minute timer).   | Periodic_Vboost         |

### Battery Charging Voltage Over Time

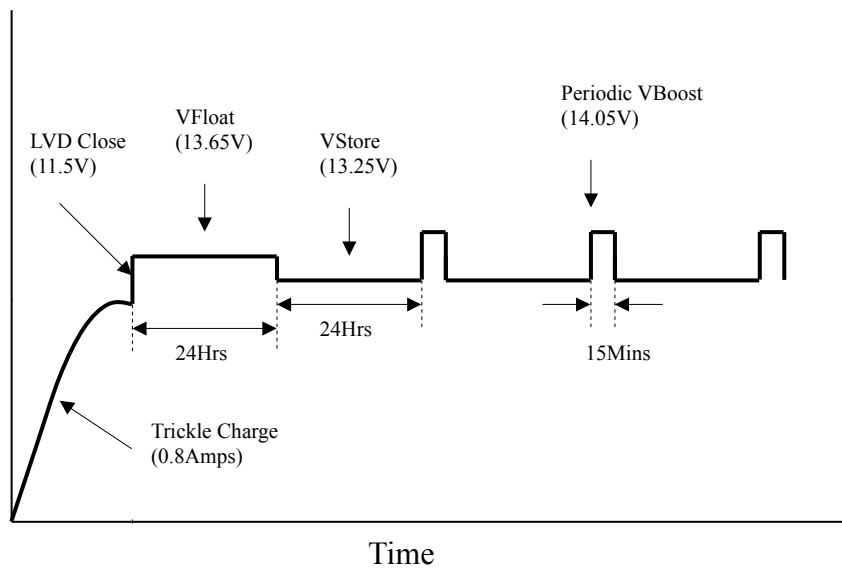

## Electromagnetic compatibility (EMC)

Electromagnetic compatibility (EMC) is defined as “the ability of a device, equipment or system to function satisfactorily in its electromagnetic environment without introducing intolerable electromagnetic disturbance to anything in that environment”.

Switch-mode power supplies are good generators of EMI and as such care needs to be taken during their designs to limit their emissions. Requirements of the local regulator (ACA) limit the emissions to protect the frequency spectrum. Limits are set down in standards such as EN55022 for radiated and conducted emissions. However, these limits are not satisfactory for devices in close proximity (<3m) and as such do not guarantee that the power supply will not cause interference with devices such as TV’s or radios.

The ST20-III/35-III have been designed with equipment interoperability in mind. The emissions are in the order of 10 – 100 times below the regulator requirements (this is expressed in dB ( $\mu$ V)) and greatly reduce the likelihood of causing interference with Radios and TV’s located in close proximity.

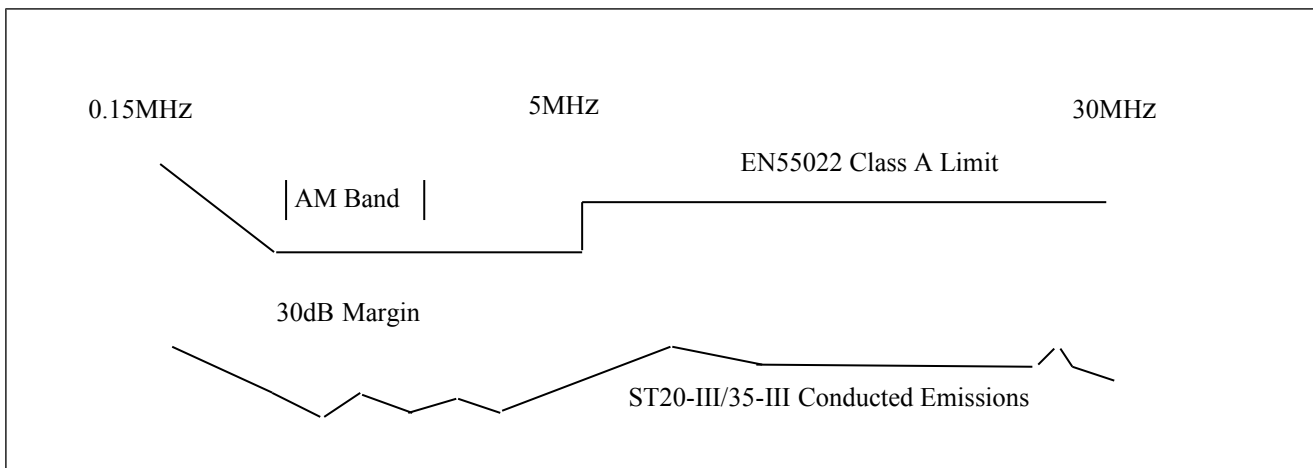

However, care still needs to be taken with the routing of cables and placement of the unit with respect to appliances. Small emissions can still cause interference. *If interference is present, then locate cables from the power supply away from appliance so far as possible and also locate the power supply away as far as practical.*